



# Application Alley

**PARTNER | SOLVE | DELIVER**

## **Telecomm - Reed Sensor**

**Animal Tracking Devices Use Reed Sensors**



Custom  
Engineered  
Solutions for  
Tomorrow

## Introduction

Many animal species are on the decline for a multitude of potential reasons. Tracking the animals is the best way to study their habits in their natural habitats. This approach has yielded the best results in determining the decline of the species. To accomplish this, microelectronic circuits are added to a collar or can be implanted into the animal. A micro reed sensor, which draws no power, in these thrifty battery powered devices, is used to extract information from the micro-circuitry.

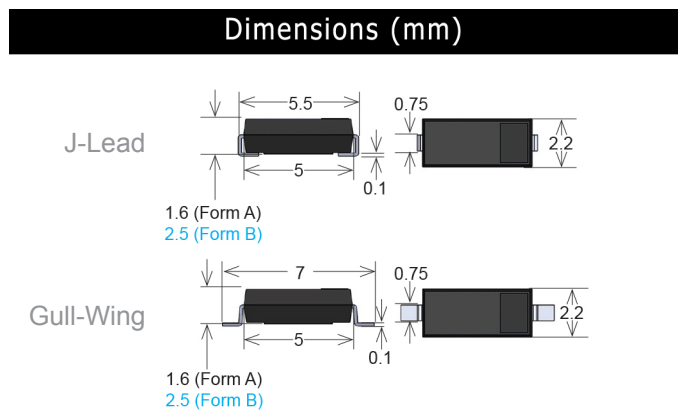

Figure 1. MK24 Sensor physical layout

## Features

- One of the smallest reed sensors on the market
- The reed switch used in the Reed Sensor is hermetically sealed and is therefore not sensitive to wet, moist environments
- The micro sensor is not influenced by temperature extremes
- The micro reed sensor is capable of animal implantation.
- Surface mounting from tape and reel
- Contacts dynamically tested
- High reliability
- Zero power consumption

## Applications

- Ideal for use where space is critical particularly in battery operated devices and where body implantation is a requirement

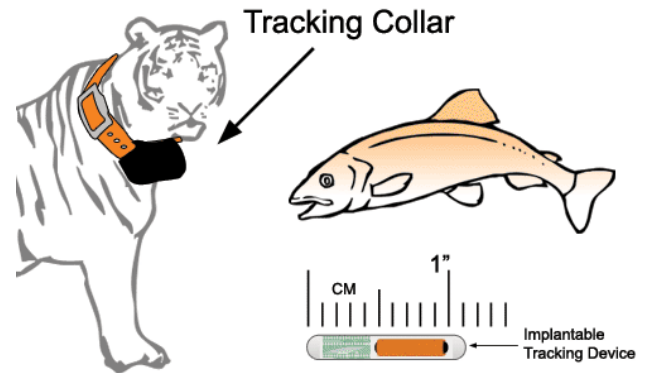

Figure 2. Implantable tracking device with built in micro reed sensor device.

## Micro Reed Sensor Allows Retrieval of Vital Migratory Habits of Endangered Animals

Several animals are on the endangered list. To prevent them from becoming extinct, the government and private donors have set up programs, such as the development of tracking devices that are worn on a collar and/or implanted in the animal. The implanted device has proven to be more reliable, as the collars wear over time or can be torn off by their host. These tracking devices must be very small, and of course, are battery operated. When the implanted tracking device is used, after the animal has been tracked for a given period of time, they are caught and tranquilized. Then a magnet is brought up to the implanted device, closing Standex-Meder's hermetically sealed micro reed sensor, which here-to-fore has drawn zero power. The sensor then turns on a transmitter which wirelessly transmits all of the tracking information into a receiver. The tracking information can then be analyzed, and decisions can be made on how to help the animal better survive.

Because Standex-Meder’s sensors use hermetically sealed reed switches that are further packaged in strong high strength plastic, they can be subject to rough treatment and environmental concerns such as grit, water, and moisture without any loss of reliability.

Standex-Meder’s sensors are packaged for surface mounting and can be supplied in tape and reel for ease of manufacturing

Specifications (@ 20°C) MK24 Series			
	Min	Max	Units
<b>Operate Specifications</b>			
Must close distance	1.7	4.4	mT
Must open distance	0.7		mT
Hysteresis	Typical 50%		
<b>Load characteristics</b>			
Switching voltage		30	V
Switching current		0.3	Amps
Carry current		0.3	Amps
Contact rating		3	Watts
Static contact resistance	100	250	mΩ
Dynamic contact resistance	100	250	mΩ
Breakdown voltage	60		V
Operate time		1.0	msec
Release time		0.5	msec
Operate temp	-40	130	°C
Storage temp	-50	130	°C

Surface Mount Sensor Series			
Series	Dimensions		Illustration
	mm	inches	
MK24	W	2.2 / 0.086	
	H	1.6 / 0.063	
	L	5.0 / 0.195	

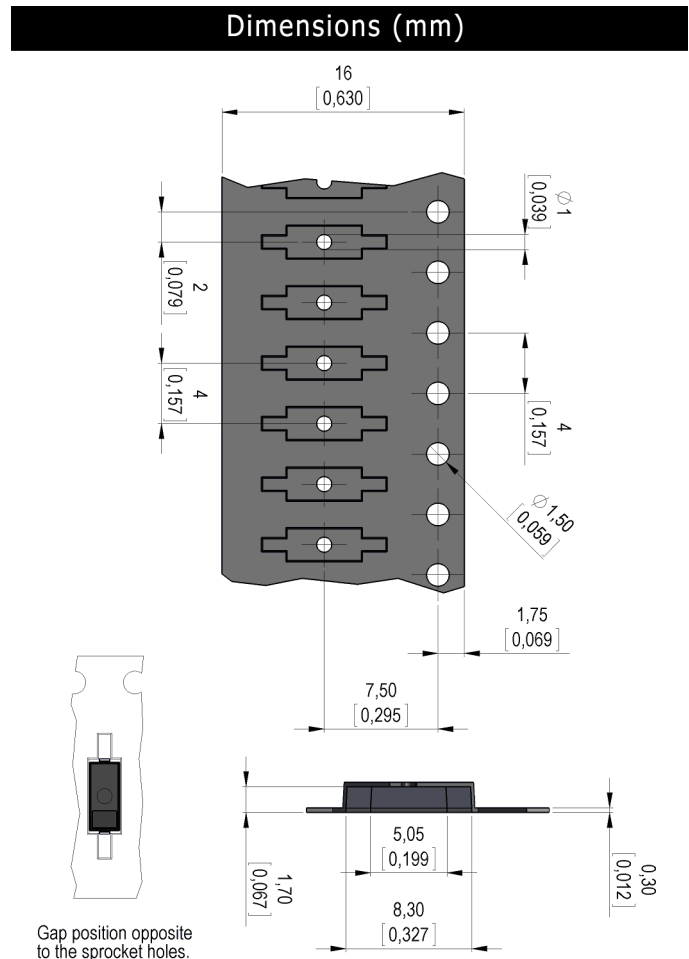

Figure 3. MK24 Tape & Reel

Find out more about our ability to propel your business with our capabilities and solutions by visiting [www.standexmeder.com](http://www.standexmeder.com). Give us a [hello@standexelectronics.com](mailto:hello@standexelectronics.com) today! One of our engineers or sales leaders will engage your team.

## About Standex-Meder Electronics

Standex-Meder Electronics is a worldwide market leader in the design, development and manufacture of standard and custom electro-magnetic components, including magnetics products and reed switch-based solutions.

Our magnetic offerings include planar, Rogowski, current, and low- and high-frequency transformers and inductors. Our reed switch-based solutions include Meder, Standex and OKI brand reed switches, as well as a complete portfolio of reed relays, and a comprehensive array of fluid level, proximity, motion, water flow, HVAC condensate, hydraulic pressure differential, capacitive, conductive and inductive sensors.

We offer engineered product solutions for a broad spectrum of product applications in the automotive, medical, test and measurement, military and aerospace, as well as appliance and general industrial markets.

Standex-Meder Electronics has a commitment to absolute customer satisfaction and customer-driven innovation, with a global organization that offers sales support, engineering capabilities, and technical resources worldwide.

Headquartered in Cincinnati, Ohio, USA, Standex-Meder Electronics has eight manufacturing facilities in six countries, located in the United States, Germany, China, Mexico, the United Kingdom, and Canada.

For more information on Standex-Meder Electronics, please visit us on the web at [www.standexmeder.com](http://www.standexmeder.com).

### Contact Information:

Standex-Meder Electronics  
World Headquarters  
4538 Camberwell Road  
Cincinnati, OH 45209 USA

**Standex Americas (OH)**  
+1.866.STANDEX (+1.866.782.6339)  
[info@standexelectronics.com](mailto:info@standexelectronics.com)

**Meder Americas (MA)**  
+1.800.870.5385  
[salesusa@standexmeder.com](mailto:salesusa@standexmeder.com)

**Standex-Meder Asia (Shanghai)**  
+86.21.37820625  
[salesasia@standexmeder.com](mailto:salesasia@standexmeder.com)

**Standex-Meder Europe (Germany)**  
+49.7731.8399.0  
[info@standexmeder.com](mailto:info@standexmeder.com)